

Hydraulic cylinders type **CH** - big bore sizes

to ISO 6020-3 - nominal pressure 16 MPa (160 bar) - max 25 MPa (250 bar)

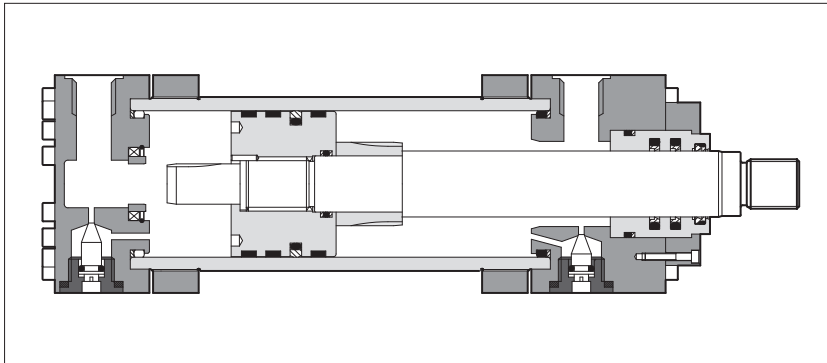

CH big bore cylinders have engineered double acting construction, designed to suit the requirements of industrial applications: top reliability, high performances and long working life.

- Bore sizes from **250** to **400** mm
- Strokes up to **5000** mm
- **7** standard mounting styles
- **2** seals options
- **3** piston guides for overload
- Adjustable cushionings
- Optional built-in position transducer, **see tab. B310**
- Attachments for rods and mounting styles, **see tab. B500**

For cylinder's choice and sizing criteria **see tab. B015**.



DVC Cylinder Designer

The configuration and options of CH big bore cylinders are easily selectable with the DVC software. Once the cylinder code is correctly defined using the configurator tool, the relevant 3D modelling and imaging are immediately available for the user.

1 MODEL CODE

CH	F	250 / 140 * 0500	S	3	0	8	A	B1E3X1Z3	**
<p>CYLINDERS SERIES CH to ISO 6020 - 3</p> <p>ROD POSITION TRANSDUCER F = magnetosonic M = magnetosonic programmable N = magnetostrictive P = potentiometric V = inductive Dimensions and performances see tab. B310</p> <p>BORE SIZE, see section 3 from 250 to 400 mm</p> <p>ROD DIAMETER, see section 7 from 140 to 220 mm</p> <p>STROKE, see section 4 up to 5000 mm</p> <p>MOUNTING STYLE, see sections 2 and 3</p> <p>C = fixed clevis G = front trunnion L = intermediate trunnion N = square front flange P = square rear flange S = fixed eye with spherical bearing X = basic execution</p> <p>REF. ISO MP1 MT1 MT4 * MF5 MF6 MP5 -</p> <p>* XV dimension must be indicated in the model code, see section 3 - note (5)</p>							<p>HEADS' CONFIGURATION (2), see section 11</p> <p>Oil ports positions B1 = front head X1 = rear head</p> <p>Cushioning adjustments positions E3 = front head Z3 = rear head</p> <p>OPTIONS (2): Rod treatment, see section 9 T = induction surface hardening and chrome plating</p> <p>Air bleeds, see section 13 A = front air bleed W = rear air bleed</p> <p>Draining, see section 14 L = rod side draining</p> <p>Flange oil ports, see section 6 M = front and rear SAE 6000 flange oil ports</p> <p>SEALING SYSTEM, see section 12 2 = (FKM + PTFE) very low friction and high temperatures 8 = (NBR + PTFE and POLYURETHANE) low friction</p> <p>SPACER, see section 5 0 = none 2 = 50 mm 4 = 100 mm 6 = 150 mm 8 = 200 mm</p> <p>CUSHIONINGS, see section 10 0 = none Slow adjustable 1 = rear only 2 = front only 3 = front and rear</p>	<p>Series number (1)</p>	

Notes:

- (1) For spare parts request always indicate the series number printed on the nameplate
(2) To be entered in alphabetical order

2 MOUNTING STYLE - for dimensions see section **3**

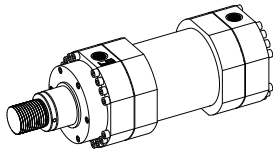

X = basic mounting

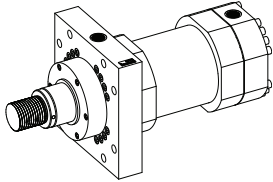
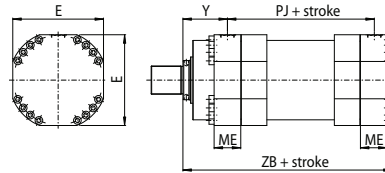

N (ISO MF5) = front flange mounting

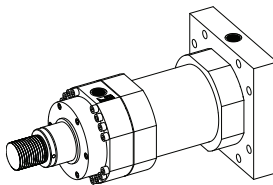
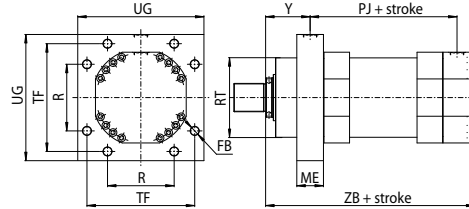

P (ISO MF6) = rear flange mounting

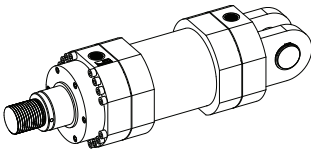
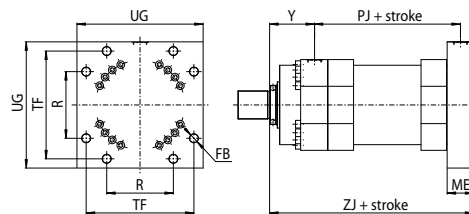

C (ISO MP1) = fixed clevis mounting - supplied with pivot pin C-145

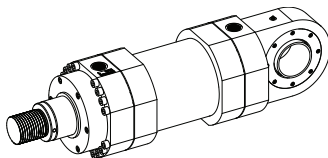
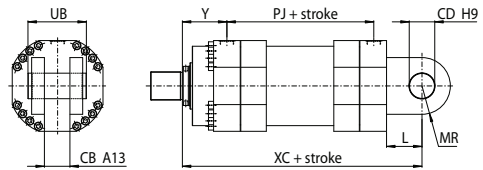

S (ISO MP5) = fixed eye with spherical bearing mounting

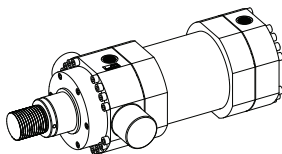
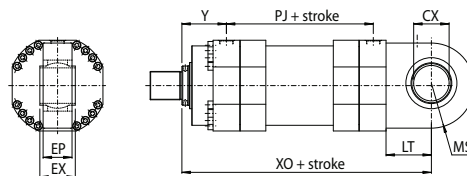

G (ISO MT1) = front trunnion mounting

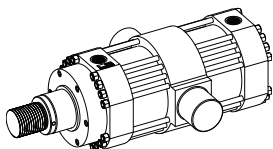
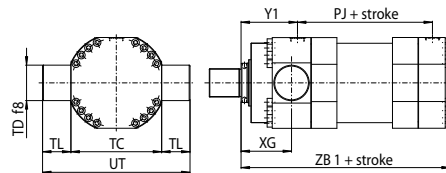

L (ISO MT4) = intermediate trunnion mounting

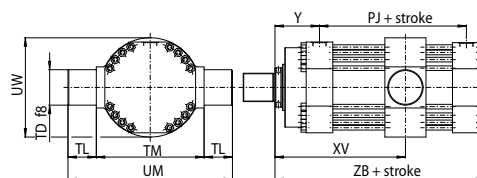

3 INSTALLATION DIMENSIONS [mm] - see figures in section **2**

Ø Bore	250	320	400	
Ø Rod	140	180	220	
B f9 (4)	163	205	245	
CB A13	90	110	140	
CD H9	90	110	140	
CX H7	125	160	200	
D (1)	58	58	69	
E (2) max	320	400	500	
EE (1)	G 1 1/2	G 1 1/2	G 2	
EP	102	130	162	
EX	125	160	200	
F max (4)	75	75	75	
FB	30	36	45	
L min	125	152	195	
LT min	160	200	250	
ME ref	94	114	140	
MR max	100	120	160	
MS max	160	200	250	
MT (3) [Nm]	350	680	1060	
PJ ±1,5 (6)	218	252	320	
R js13	235	283	340	
RD f8 (4)	280	325	380	
TC h14	320	400	500	
TD f8	125	160	200	
TF	380	472	588	
TL	100	125	160	
TM h14	380	485	605	
UB	180	220	280	
UG max	445	549	683	
UM ref	580	735	925	
UT ref	520	650	820	
UW max	480	600	750	
VD min (4)	8	8	8	
VE max (4)	83	83	83	
WF ±2	110	110	110	
XC ±1,5 (6)	545	627	775	
XG ±2 (6)	178	195	215	
XO ±1,5 (6)	580	675	830	
XV (5)	style L	20	35	26
	min	275	312	358
	max	255+stroke	273+stroke	332+stroke
Y ±2 (6)	157	167	180	
Y1 ±2 (6)	199	223	260	
ZB max (6)	460	520	625	
ZB1 max (6)	505	580	685	
ZJ ±1 (6)	420	475	580	

NOTES TO TABLE 3

(1) **D, EE** - Oil ports and drain are threaded according to GAS standard with counter-bore dimension **D** according to ISO 1179-1 (see figure below)

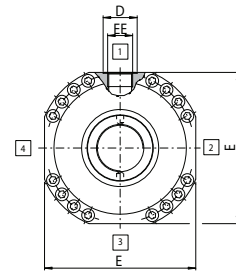

(2) **E** - If not otherwise specified in the figures in section **2**, this value is the front and rear round heads dimension for all the mounting styles (see figure above)

(3) **MT** - Screws tightening torque. Mounting screws must be to a minimum strength of ISO 898/2 grade 12.9

(4) See figures in section **7**

(5) **XV** - For cylinders with mounting style **L** the stroke must always exceed the minimum values reported in the table. The requested **XV** value must be included between **XV min** and **XV max** and it must be always indicated, with dimension in millimeters, together with the cylinder code. See the following example:

CH - 250 / 140 * 0500 - L308 - A - B1E3X1Z3
XV = 300

(6) The tolerance is valid for strokes up to 1250 mm, for longer strokes the upper tolerance is given by the max stroke tolerance in section **4**

4 STROKE SELECTION

Stroke has to be selected a few mm longer than the working stroke, to prevent to use the cylinder heads as mechanical stroke-end. The table below shows the minimum stroke depending to the bore.

Minimum stroke [mm]

Ø Bore	250	320	400
Minimum stroke	65	70	40

Maximum stroke:

- 5000 mm

Stroke tolerances:

- 0 +2 mm for strokes up to 1250 mm
- 0 +5 mm for strokes from 1250 to 3150 mm
- 0 +8 mm for strokes over 3150 mm

5 SPACER

For strokes longer than 1000 mm, proper spacers have to be introduced in the cylinder's construction to increase the rod and piston guide and to protect them from overloads and premature wear. Spacers can be omitted for cylinders working in traction mode. The introduction of spacers increases the overall cylinder's dimensions: spacers' length has to be added to all stroke dependent dimensions in section **3**.

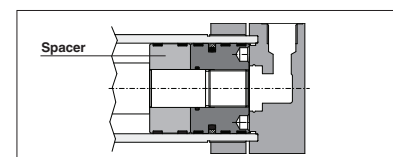

RECOMMENDED SPACERS [mm]

Stroke	1001 ÷ 1500	1501 ÷ 2000	2001 ÷ 2500	2501 ÷ 5000
Spacer code	2	4	6	8
Length	50	100	150	200

6 SAE 6000 FLANGE OIL PORTS - DIMENSIONS TO ISO 6162-2 [mm]

Ø Bore	DN	EA ±0,25	EB ±0,25	ED 6g	FF -1,5 / 0
250	38	36,5	79,3	M16	38
320					
400	51	44,5	96,8	M20	51

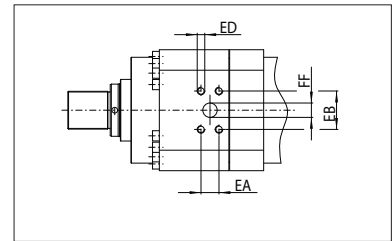

7 ROD END DIMENSIONS [mm]

Ø Bore	250	320	400
Ø Rod	140	180	220
A	112	125	160
CH (*)	15	15	15
KK	M100x3	M125x4	M160x4

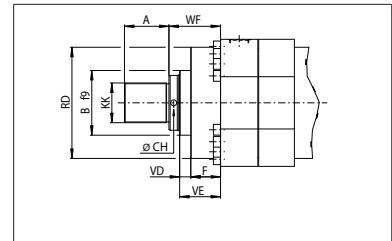

(*) n°2 holes per key

Note: for B, F, RD, VD, VE and WF dimensions see section 3

8 CYLINDER'S HOUSING FEATURES

The cylinder's housings are made in "hot rolled steel" with $R_s = 360 \text{ N/mm}^2$; the internal surfaces are lapped: diameter tolerance H8, roughness $R_a \leq 0,25 \mu\text{m}$.

9 RODS FEATURES and options

The rods materials have high strength, which provide safety coefficients higher than 4 in static stress conditions, at maximum working pressure. The rod surface is chrome plated: diameter tolerances f7; roughness $R_a \leq 0,25 \mu\text{m}$. Corrosion resistance of 100h in neutral spray to ISO 9227 NSS.

Ø Rod	Material	Rs min [N/mm ²]	Chrome	
			min thickness [mm]	hardness [HV]
140	alloy-steel	450	0,020	850-1150
180÷220	carbon steel	360	0,045	

The rod and piston are mechanically coupled by a threaded connection in which the thread on the rod is at least equal to the external thread KK, indicated in the table 7. See tab. B015 for the prediction of the expected rod fatigue life. The piston is screwed to the rod by a prefixed tightening torque in order to improve the fatigue resistance. The stop pin ① avoids the piston unscrewing. Contact our technical office in case of heavy duty applications.

Rod hardness can be improved selecting the option T:
 • T = Induction surface hardening and chrome plating (only for rod 140)
 • 56-60 HRC (613-697 HV) hardness

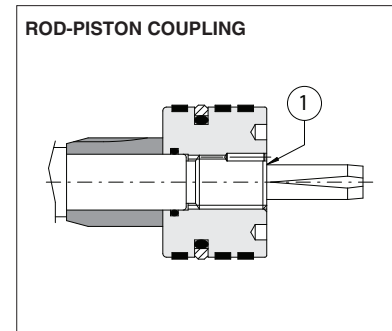

10 CUSHIONINGS

Cushionings are recommended for applications where: • the piston makes a full stroke with speed over than 0,05 m/s; • it is necessary to reduce undesirable noise and mechanical shocks; • vertical application with heavy loads. The stroke-end cushionings are hydraulic dampers specifically designed to dissipate the energy of the mass connected to the cylinder rod, by progressively increasing the pressure in the cushioning chamber and thus reducing the rod speed before the cylinder's mechanical stroke-end (see the graphics at side). See the tab. B015 for the max damping energy. The cylinder is provided with needle valve to optimize cushioning performances in different applications. The regulating screws are supplied fully screwed in (max cushioning effect). In case of high masses and/or very high operating speeds it is recommended to back them off to optimize the cushioning effect. The adjustment screw has a special design to prevent unlocking and expulsion. The cushioning effect is highly ensured even in case of variation of the fluid viscosity.

L_f is the total cushioning length. When the stroke-end cushionings are used as safety devices, to mechanically preserve the cylinder and the system, it is advisable to select the cylinder's stroke longer than the operating one by an amount equal to the cushioning length L_f ; in this way the cushioning effect does not influence the movement during the operating stroke.

Ø Bore	250	320	400	
Ø Rod	140	180	220	
Cushioning length [mm]	Lf front	50	60	70
	Lf rear	56	64	64

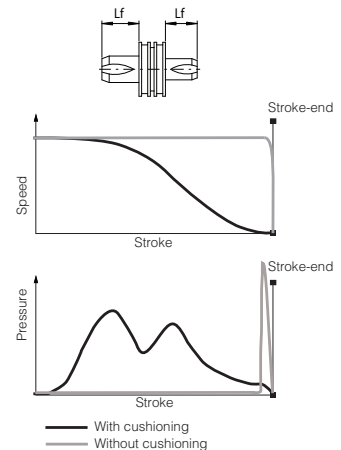

11 POSITION OF THE OIL PORTS AND CUSHIONING ADJUSTMENTS

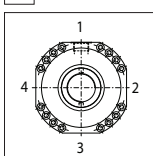

FRONT HEAD: B1 = oil port position; E3 = cushioning adjustment position
 REAR HEAD: X1 = oil port position; Z3 = cushioning adjustment position.
 The oil ports and cushioning adjustment positions are only available, respectively, on sides 1 and 3 (see the figure at side).

Example of model code: CH-250/140 *0100-S301 - A - B1E3X1Z3

12 SEALING SYSTEM FEATURES

The sealing system must be chosen according to the working conditions of the system: speed, operating frequencies, fluid type and temperature. Special sealing system for low temperatures, high frequencies (up to 20 Hz), long working life and heavy duty are available on request. All the seals, static and dynamic, must be periodically replaced: proper spare kits are available, see section 18. Contact our technical office for the compatibility with other fluids not mentioned below and specify type and composition. See section 13 for fluid requirements.

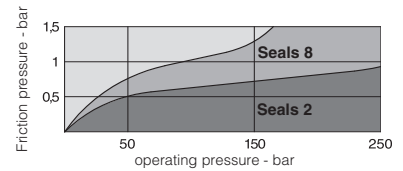

Sealing system	Material	Features	Max speed [m/s]	Fluid temperature range	Fluids compatibility	ISO Standards for seals	
						Piston	Rod
2	FKM + PTFE	very low friction and high temperatures	4	-20°C to 120°C	Mineral oils HH, HL, HLP, HLP-D, HM, HV, fire resistance fluids HFA, HFB, HFD-U, HFD-R	ISO 7425/1	ISO 7425/2
8	PTFE + NBR + POLYURETHANE	low friction	1	-20°C to 85°C	Mineral oils HH, HL, HLP, HLP-D, HM, HV	ISO 7425/1	ISO 7425/2

13 AIR BLEEDS

CODES: **A** = front air bleed; **W** = rear air bleed

The air in the hydraulic circuit must be removed to avoid noise, vibrations and irregular cylinder's motion: air bleed valves are recommended to realize this operation easily and safely.

Air bleeds are positioned on side 3, see section 11.

For a proper use of the air-bleed (see figure on side) unlock the grub screw ① with a wrench for hexagonal head screws, bleed-off the air and retighten as indicated in table at side.

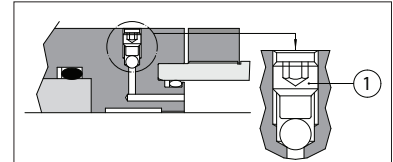

Ø Bore	Screwing	Tightening torque
250	M8 x 10	20 Nm
320 - 400	M12 x 20	30 Nm

14 DRAINING

CODE: **L** = rod side draining

The rod side draining reduces the seals friction and increases their reliability; it is mandatory for cylinders with strokes longer than 2000 mm, with rod side chamber constantly pressurized and for servocylinders.

The draining is positioned on the same side of the oil port, between the wiper and the rod seals (see figure at side). It is recommended to connect the draining port to the tank without backpressure. Draining port is G1/8.

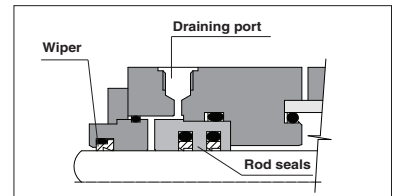

15 FLUID REQUIREMENTS

Cylinders and servocylinders are suitable for operation with mineral oils with or without additives (**HH, HL, HLP, HLP-D, HM, HV**), fire resistant fluids (**HFA** oil in water emulsion - 90-95% water and 5-10% oil, **HFB** water in oil emulsion - 40% water, **HFC** water glycol - max 45% water) and synthetic fluids (**HFD-U** organic esters, **HFD-R** phosphate esters). The fluid must have a viscosity within 15 and 100 mm²/s, a temperature within 0 and 70°C and fluid contamination class ISO 19/16 according to ISO 4406, achieved with in-line filters at 25 µm.

16 CYLINDERS MASSES [kg] (tolerance ± 5%)

Ø Bore [mm]	Ø Rod [mm]	MASS FOR STYLE X single rod		ADDITIONAL MASSES according to mounting styles and options						
		Stroke 100 mm	Each 100 mm more	Styles C, S	Style G	Style L	Styles N, P	Front cushioning	Rear cushioning	Each 50 mm spacer
250	140	324	27	55	9	110	83	8,5	19	28
320	180	485	41	82	16	160	142	11	27	44
400	220	902	71	155	34	360	275	17	45	72,4

Note: the masses related to the other options, not indicated in the table, don't have a relevant influence on the cylinder's mass

17 CYLINDER SECTION

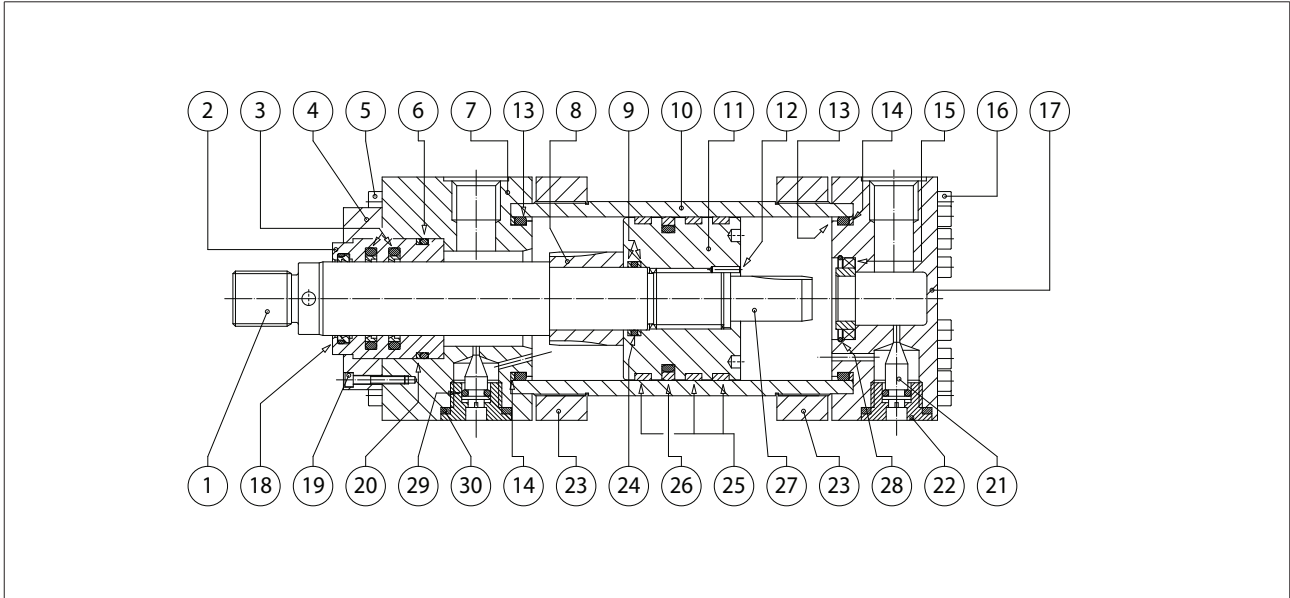

POS.	DESCRIPTION	MATERIAL	POS.	DESCRIPTION	MATERIAL	POS.	DESCRIPTION	MATERIAL
1	Rod	Chrome plated steel	11	Piston	Steel	21	Cushioning adjustment screw	Steel
2	Rod bearing	Bronze	12	Screw stop pin	Steel	22	Cushioning adjustment plug	Steel
3	Rod seal	NBR + PTFE	13	O-ring	NBR / FKM	23	Counterflange	Steel
4	Flange	Steel	14	Anti-extrusion ring	PTFE	24	O-ring	NBR / FKM
5	Screw	Steel	15	Rear cushioning sleeve	Bronze	25	Piston guide ring	PTFE
6	O-ring	NBR / FKM	16	Screw	Steel (grade 12.9)	26	Piston seal	NBR / FKM + PTFE
7	Front head	Steel	17	Rear head	Steel	27	Rear cushioning piston	Steel
8	Front cushioning piston	Hardened steel	18	Wiper	NBR / FKM + PTFE	28	Toroidal ring	Steel
9	Anti-extrusion ring	PTFE	19	Screw	Steel	29	O-ring and anti-extrusion ring	NBR / FKM + PTFE
10	Cylinder housing	Steel	20	Anti-extrusion ring	PTFE	30	Bonded seal	Steel

18 MODEL CODE FOR SEALS SPARE PARTS

SP - G 8 - CH - 250 / 140 - 01

Seals spare code							
Sealing system							Series number
Cylinder series							
Bore size [mm]							Rod diameter [mm]