



Educational Systems, LLC

105 Webster St. Hanover Massachusetts 02339 Tel. 781 878 1512 Fax 781 878 6708 www.gearseds.com

Spur Gear Terms and Concepts

Description

In order to design, build and discuss gear drive systems it is necessary to understand the terminology and concepts associated with gear systems. Good designers and engineers have experience and knowledge and the ability to communicate their thoughts and ideas clearly with others. The students and teachers who participate in this unit will learn the gear terms and concepts necessary to design, draw and build gear drive systems, and improve their “Gear literacy”.

Standards Addressed

National Council of Teachers of English Standards (<http://www.readwritethink.org/standards/index.html>)

- Students adjust their use of spoken, written, and visual language (e.g., conventions, style, vocabulary) to communicate effectively with a variety of audiences and for different purposes.
- Students conduct research on issues and interests by generating ideas and questions, and by posing problems. They gather, evaluate, and synthesize data from a variety of sources (e.g., print and non-print texts, artifacts, people) to communicate their discoveries in ways that suit their purpose and audience.
- Students participate as knowledgeable, reflective, creative, and critical members of a variety of literacy communities.
- Students use spoken, written, and visual language to accomplish their own purposes (e.g., for learning, enjoyment, persuasion, and the exchange of information).

National Council of Mathematics Teachers

(9-12 Geometry Standards) (<http://standards.nctm.org/document/appendix/geom.htm>)

- Analyze properties and determine attributes of two- and three-dimensional objects
- Explore relationships (including congruence and similarity) among classes of two- and three-dimensional geometric objects, make and test conjectures about them, and solve problems involving them;

(9-12 Algebra Standards) <http://standards.nctm.org/document/chapter7/alg.htm>

- Understand and perform transformations such as arithmetically combining, composing, and inverting commonly used functions, using technology to perform such operations on more-complicated symbolic expressions.
- Understand the meaning of equivalent forms of expressions, equations, inequalities, and relations
- Use symbolic algebra to represent and explain mathematical relationships;

(9-12) Science and Technology Standards (from the National Science Standards web page)

<http://www.nap.edu/readingroom/books/nse/html/6a.html#unifying>

- The abilities of design. Using math to understand and design gear forms is an example of one aspect of an ability to design.

Terms

Active Profile	Diametral Pitch	Pressure Angle
Addendum	Gear Ratios	Profile
Backlash	Herringbone Gears	Rack
Base Circle	Idler Gear	Spur Gear
Center Distance	Involute	Velocity
Chordal Thickness	Module	Whole Depth
Circular Pitch	Pitch	Working Depth
Circular Thickness	Pitch Diameter	
Dedendum	Pitch Point	

Materials/Equipment/Supplies/Software

Pencils	1-2' String
8-1/2 x 11" Paper	Tin Can
Compass	Tape
Protractor	GEARS-IDS Kit
Ruler	GEARS-IDS Optional Gear Set
Straight Edge	

Objectives.

Students who participate in this unit will:

1. Sketch and illustrate the parts of a spur gear.
2. Calculate gear and gear tooth dimensions using gear pitch and the number of teeth.
3. Calculate center to center distances for 2 or more gears in mesh.
4. Calculate and specify gear ratios.

Some Things to Know Before You Start

How to use a compass

How to use a protractor to measure angles

How to solve simple algebraic expression.

Basic Geometric Terms

Gear Terms and Types

Spur gears have been used since ancient times. Figure 6.3.1.1 shows an illustration of the two-man drive system that Leonardo Davinci designed to power a his vision of a helicopter like device. The device never flew, but the gear system works.

Modern gears are a refinement of the wheel and axle. Gear wheels have projections called teeth that are designed to intersect the teeth of another gear. When

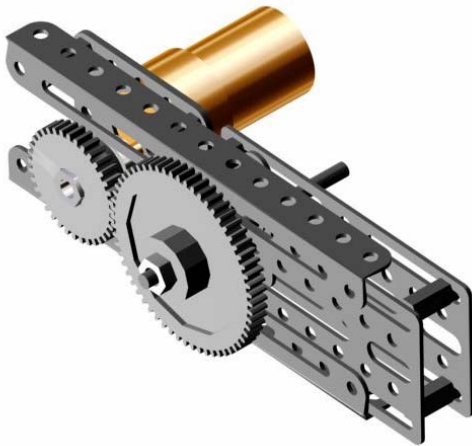

Fig. 6.3.1.2 GEARS-IDS Gear Drive system

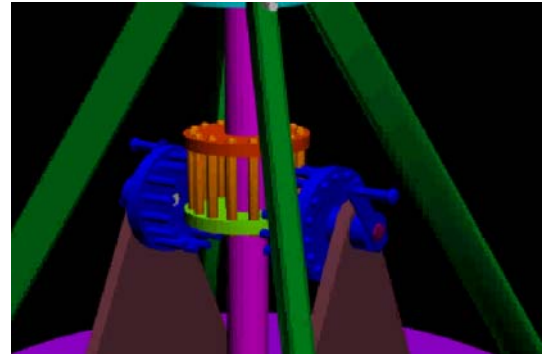

Fig. 6.3.1.1 Model of Davinci's Helicopter Gear

or
together

interlock in this manner they are said to be *in mesh*. Gears in mesh are capable of transmitting force and motion alternately from one gear to another. The gear transmitting the force or motion is called the *drive gear* and the gear connected to the drive gear is called the *driven gear*.

Gears are Used to Control Power Transmission in These Ways

1. Changing the direction through which power is transmitted (*i.e. parallel, right angles, rotating, linear etc.*)
2. Changing the amount of force or torque
3. Changing RPM

Gear Terms, Concepts and Definitions

Spur Gears

Are cogged wheels whose cogs or teeth project radially and stand parallel to the axis.

Diametral Pitch (DP)

The Diametral Pitch describes the gear tooth size. The Diametral Pitch is expressed as the number of teeth per inch of Pitch Diameter. Larger gears have fewer teeth per inch of Diametral Pitch. Another way of saying this; Gear teeth size varies inversely with Diametral Pitch.

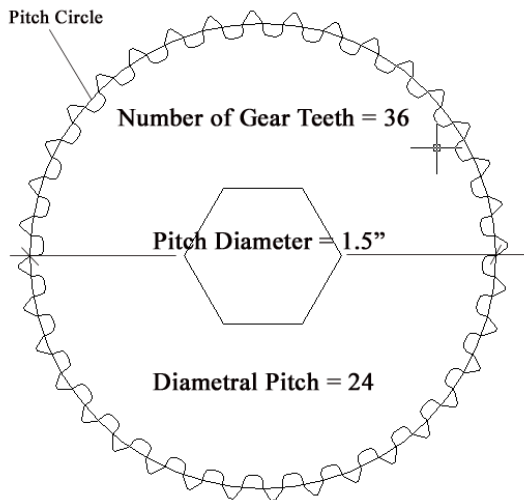

Fig. 6.3.1.3 $DP = \#Teeth/Pitch\ Diameter = 36/1.5 = 24$

Pitch Diameter (D)

The Pitch Diameter refers to the diameter of the pitch circle. If the gear pitch is known then the Pitch Diameter is easily calculated using the following formula;

$$PD = \frac{N}{P}$$

$PD =$ Pitch Diameter
 $N =$ Number of teeth on the gear
 $P =$ Diametral Pitch (Gear Size)

Using the values from fig. 6.3.1.3 we find

$$PD = \frac{N}{P} = \frac{36}{24} = 1.5"$$

The Pitch Diameter is used to generate the Pitch Circle.

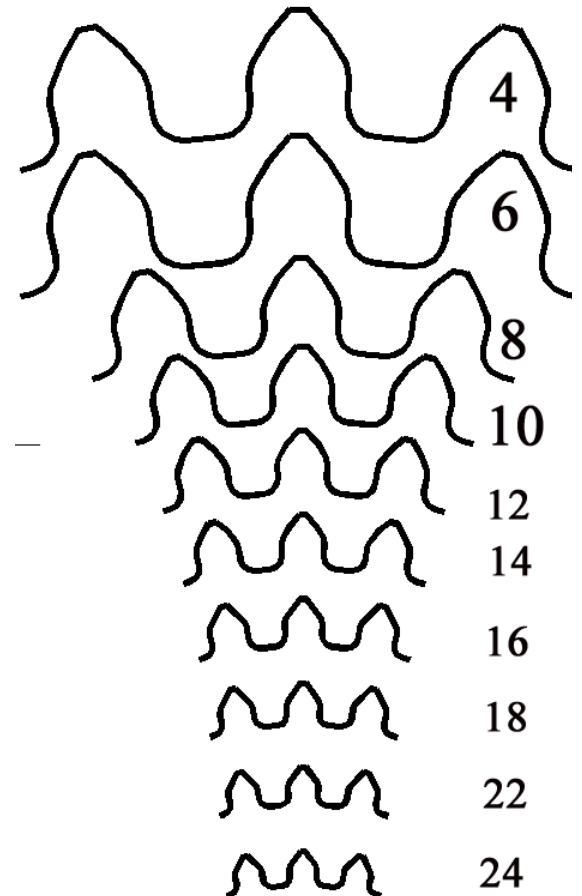
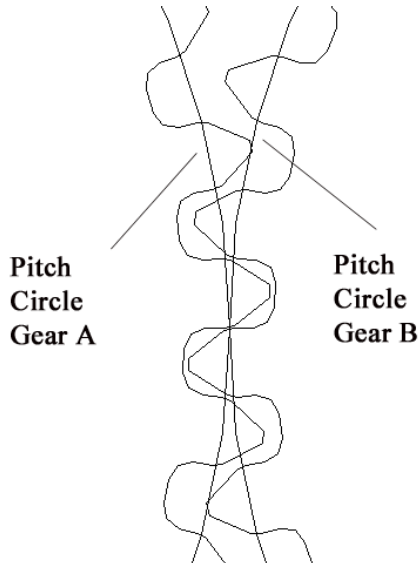

Fig. 6.3.1.4 Relative Sizes of Diametral Pitch

The Pitch Circle

The pitch circle is the geometrical starting point for designing gears and gear trains. Gear trains refer to systems of two or more meshing gears. The pitch circle is an imaginary circle that contacts the pitch circle of any other gear with which it is in mesh. See fig. 6.3.1.5 below.



The pitch circle centers are used to ensure accurate center-to-center spacing of meshing gears. The following example explains how the center distances of meshing gears is determined using the pitch circle geometry.

Example 6.3.1.1

Calculate the center-to-center spacing for the 2 gears specified below.

Gears: Gear #1) 36 tooth, 24 Pitch Drive Gear
Gear# 2) 60 tooth, 24 Pitch Driven Gear

Fig. 6.3.1.5 Pitch Circle and Gear Teeth in Mesh

Step 1.) Calculate the Pitch Diameter for each of the two gears listed above.

Pitch Diameter (D) of gear #1 is: $D = \frac{N}{P} = \frac{36}{24} = 1.5''$ Pitch Dia. = 1.5''

Pitch Diameter (d) of gear#2 is: $D = \frac{N}{P} = \frac{60}{24} = 2.5''$ Pitch Dia. = 2.5''

Step 2.) Add the two diameters and divide by 2.

$$\begin{array}{r} \text{Pitch Dia. of gear \#1} = 1.5'' \\ \text{Pitch Dia. Of gear \#2} = \underline{+ 2.5''} \end{array}$$

$$\text{Sum of both gear diameters} = 4.0''$$

Divide by 2 Sum of both gear diameters = $4.0''/2 =$ center to center distance = 2''
(This is necessary since the gear centers are separated by a distance equal to the sum of their respective radii.)

A simple formula for calculating the center-to-center distances of two gears can be written;

$$\text{Center-to-Center Distance} = \frac{D_1 + D_2}{2} \quad \text{Fig. 6.3.1.5 illustrates this relationship.}$$

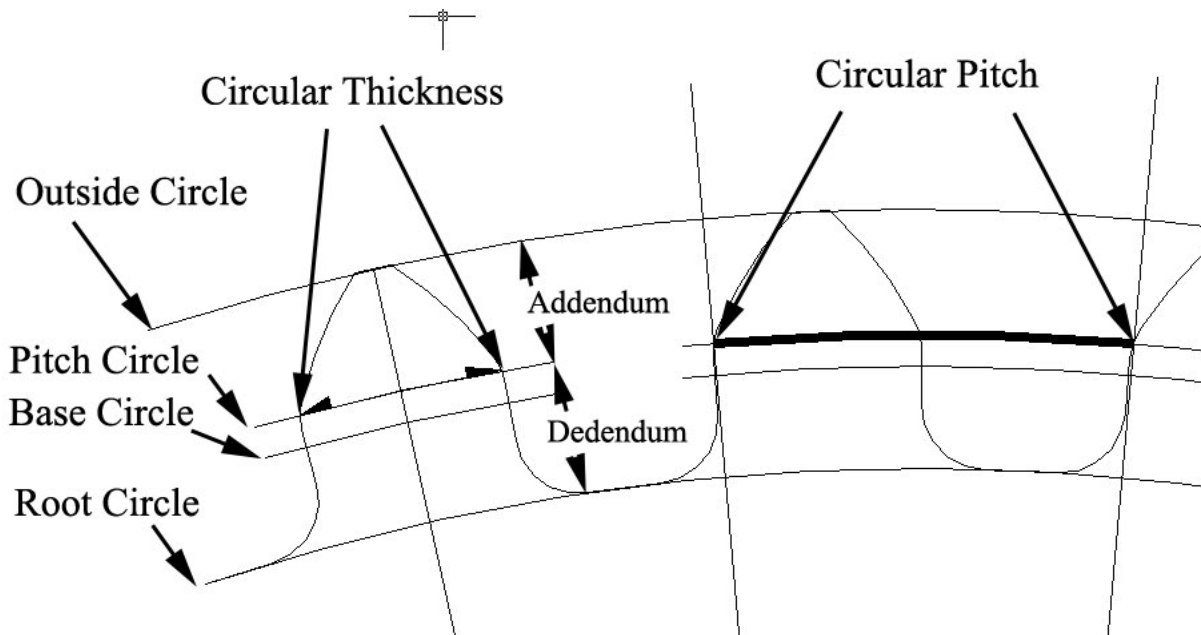

Fig. 6.3.1.5a Gear Terms Illustrated

Term	Definition	Calculation
Pitch Diameter (D)	The diameter of the Pitch Circle from which the gear is designed. An imaginary circle, which will contact the pitch circle of another gear when in mesh.	$D = \frac{N}{P}$
Diametral Pitch (P)	A ratio of the number of teeth per inch of pitch diameter	$P = \frac{N}{D}$
Addendum (A)	The radial distance from the pitch circle to the top of the gear tooth	$A = \frac{1}{P}$
Dedendum (B)	The radial distance from the pitch circle to the bottom of the tooth	$B = \frac{1.157}{P}$
Outside Diameter (OD)	The overall diameter of the gear	$OD = \frac{N + 2}{P}$
Root Diameter (RD)	The diameter at the Bottom of the tooth	$RD = \frac{N - 2}{P}$
Base Circle (BC)	The circle used to form the involute section of the gear tooth	$BC = D * \cos PA$
Circular Pitch (CP)	The measured distance along the circumference of the Pitch Diameter from the point of one tooth to the corresponding point on an adjacent tooth.	$CP = \frac{3.1416D}{N} = \frac{3.1416}{P}$
Circular Thickness (T)	Thickness of a tooth measure along the circumference of the Pitch Circle	$T = \frac{3.1416D}{2N} = \frac{1.57}{P}$

Fig. 6.3.1.5b Key Dimensions for Gear Design

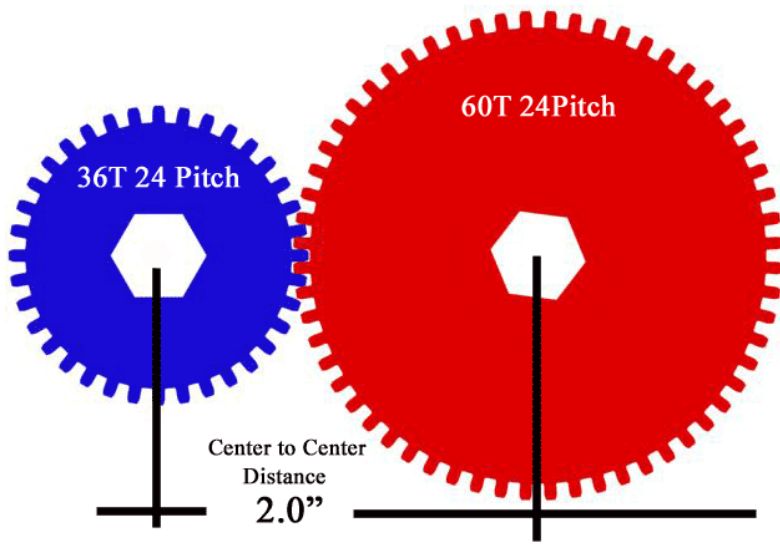

Fig. 6.3.1.6 Illustration of Center to Center Distance of Gears in Mesh

Addendum (A)

The addendum refers to the distance from the top of the tooth to the Pitch circle

Dedendum (B)

The Dedendum refers to the distance from the Pitch circle to the root circle.

Clearance (C)

Refers to the radial distance between the top and bottom of gears in mesh. Some machinists and mechanics refer to clearance as “play” or the degree of looseness between mating parts.

Whole Depth (WD)

Refers to the distance from the top of the tooth to the bottom of the tooth. The whole depth is calculated using this formula: $WD = \frac{2.157}{P}$

Pressure Angle (PA) (Choose either 14.5 or 20 degrees)

The pressure angle figures into the geometry or form of the gear tooth. It refers to the angle through which forces are transmitted between meshing gears.

14.5-degree tooth forms were the original “standard” gear design. While they are still widely available, the 20-degree PA gear tooth forms have wider bases and can transmit greater loads. *Note: 14.5-degree PA tooth forms will not mesh with 20-degree PA teeth. Be certain to verify the Pressure angle of the gears you use*

Center Distance

The center distance of 2 spur gears is the distance from the center shaft of one spur gear to the center shaft of the other. Center to center distance for two gears in mesh can be calculated with

this formula.
$$\text{Center-to-Center Distance} = \frac{PD_{gearA} + PD_{gearB}}{2}$$

Rotation

Spur gears in a 2-gear drive system (Gear #1 and Gear #2) will rotate in opposite directions. When an intermediary gear set or idler gear is introduced between the two gears the drive gear (Gear #1) and the last gear (Gear #3) will rotate in the same direction.

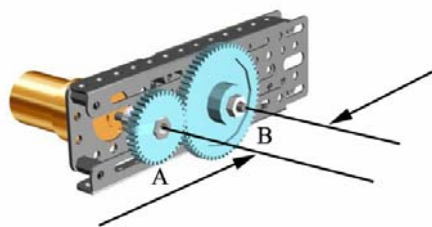

$$\text{Center to Center Distance} = \frac{PD \text{ of A} + PD \text{ of B}}{2}$$

Drive Gear #1 Rotates Clockwise



Fig. 6.3.1.7a Rotation of Two Gear Drive

designed with a specified amount of backlash to prevent noise and excessive friction and heating of the gear teeth. (See fig 6.3.1.8)

The rotational relationship between gears in a gear drive system can be stated as follows:

Two meshing gears or gear sets (Gear sets are comprised of 2 or more gears fixed to the same shaft) rotate in opposite directions. Each odd numbered gear in a gear drive rotates in the same direction.

Backlash

Backlash refers to the distance from the back of the drive gear tooth to the front of driven gear tooth of gears mated on the pitch circle. Standard gears are

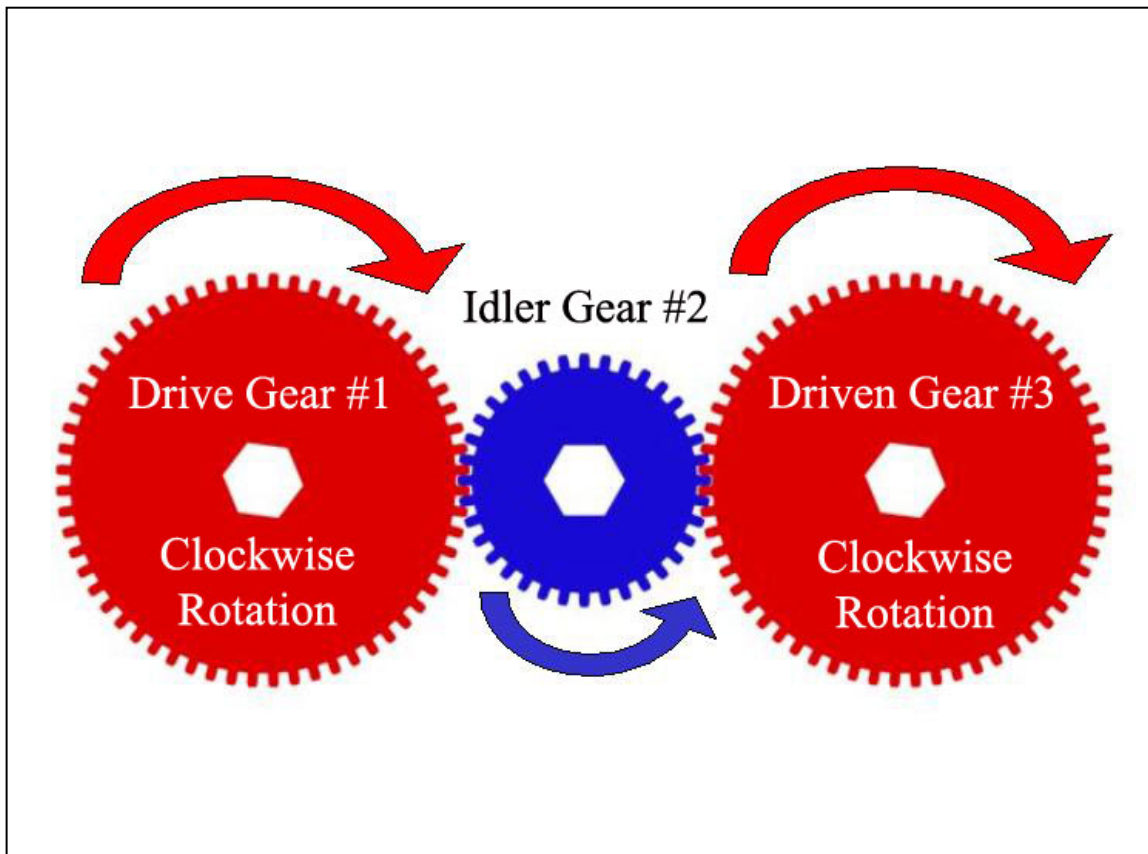

Fig. 6.3.1.7b Rotation of Three Gear Drive

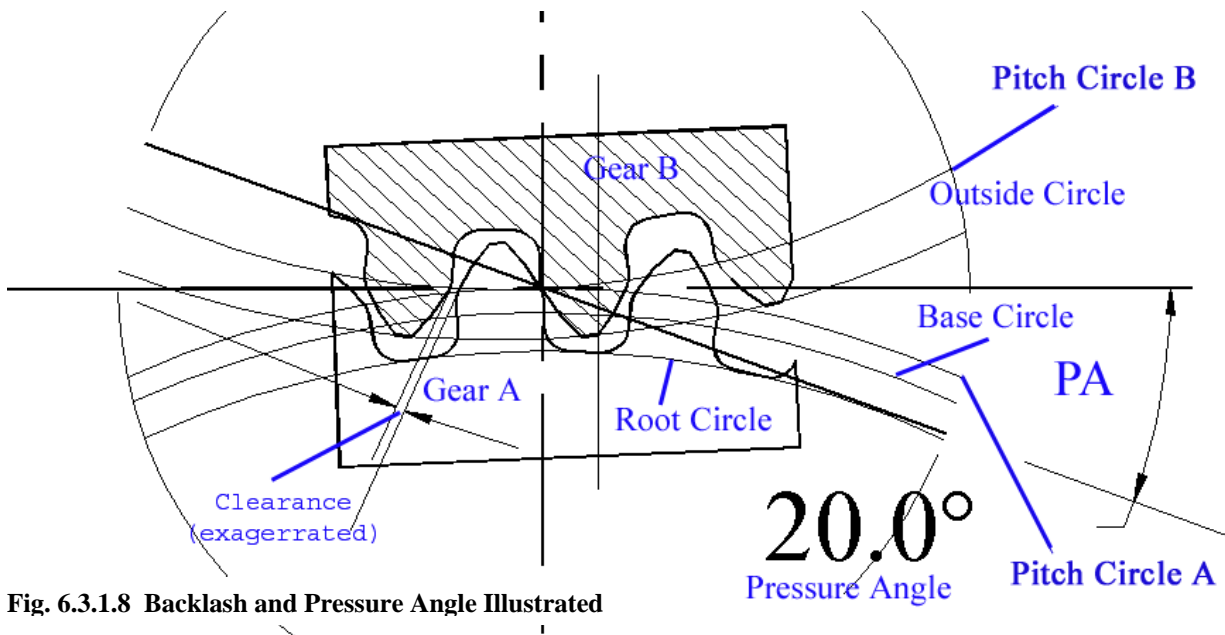

Fig. 6.3.1.8 Backlash and Pressure Angle Illustrated

Ratios

Gears of the same pitch, but differing numbers of teeth can be paired to obtain a wide range of Gear Ratios. Gear Ratios are used to increase mechanical advantage (torque) or increase rotational speed or velocity.

The ratio of a given pair of spur gears is calculated by dividing the number of teeth on the driven gear, by the number of teeth on the drive gear.

The gear ratio in fig. 6.3.1.9 shows a 36 tooth gear driving a 60 tooth gear. The gear ratio can be calculated as follows;

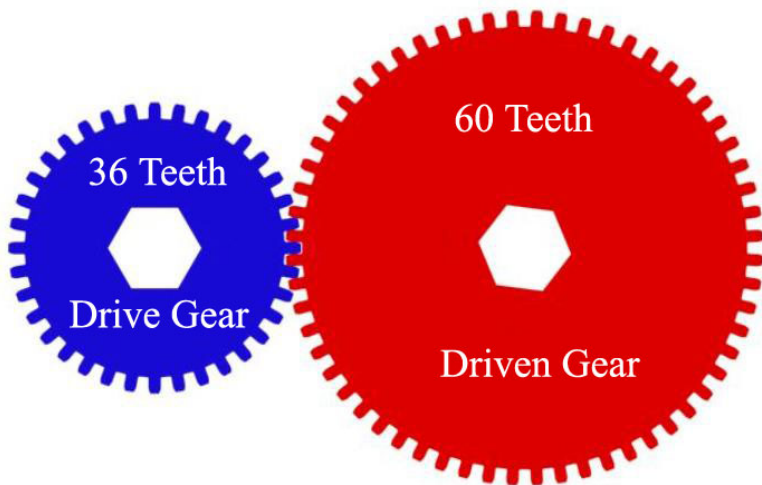

$$\text{GearRatio} = \frac{\text{DrivenGearTeeth}}{\text{DriveGearTeeth}}$$

$$\text{GearRatio} = \frac{60}{36} = 1.6 : 1$$

The ratio describes the drive gear revolutions needed to turn the driven gear 1 complete revolution.

Fig. 6.3.1.9 “Low” Gearing to increase torque

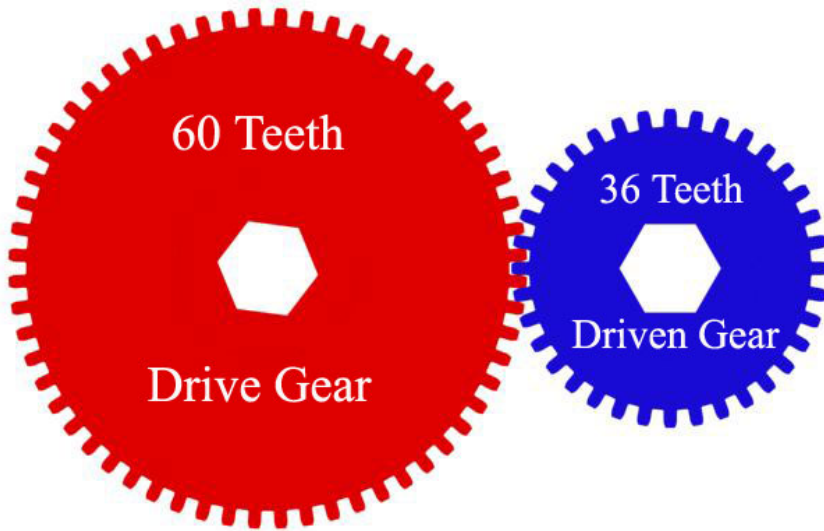

Fig. 6.3.1.10 “High” Gearing to increase Driven Gear Velocity

The 1.6:1 gear ratio increases the torque on the shaft of the large gear by 1.6X but reduces the Velocity or RPM of the large gear shaft by the same amount

The gear ratio in fig. 6.3.1.10. shows a 60 tooth gear driving a 36 tooth gear. The gear ratio is calculated the same as in the example above.

$$GearRatio = \frac{DrivenGearTeeth}{DriveGearTeeth}$$

$$GearRatio = \frac{36}{60} = 0.66 : 1 = 1 : 1.66$$

Velocity

Velocity refers to the rotational speed of a gear and can be expressed using a variety of units. In the examples that follow we will express gear velocity in inches per minute. The gear industry often uses feet per minute. Inches per minute can be converted to feet per minute by simply dividing by 12.

Velocity is expressed as the distance a point along the circumference of the pitch circle will travel over a given unit of time.

Velocity can be calculated using this formula

$$Velocity = Pitch\ Circle\ Circumference \times RPM$$

Example

The 24 pitch drive gear in fig 6.3.1.10 is turning at 100 rpm. What is the velocity of the drive gear?

Step 1.) Determine the Pitch Diameter (D) $D = \frac{\#Teeth}{Pitch} = \frac{N}{P} = \frac{60}{24} = 2.5"$

Step 2.) Determine the circumference of the Pitch Circle using the Pitch Diameter.
 $Circumference = \pi * D = 3.1416 * 2.5" = 7.854"$

Step 3.) Calculate the gear velocity using the gear velocity formula.
 $Velocity = 7.854" \times RPM = 785.4\ inches\ per\ minute\ or\ 65.45\ feet\ per\ second.$

Calculate the Velocity of the Driven Gear in the Example Above

The 36 tooth driven gear in the example above is being driven by a larger 60 tooth drive gear. In order to calculate the driven gear velocity we must first calculate the driven gear RPM using the gear ratio.

- Step 1.) Determine the driven gear RPM using the gear ratio.
Driven Gear RPM = Drive Gear RPM x ratio = 100 x 1.66 = 166 RPM
- Step 2.) Determine the Pitch Diameter (D) $D = \frac{\#Teeth}{Pitch} = \frac{N}{P} = \frac{36}{24} = 1.5"$
- Step 3.) Determine the circumference of the Pitch Circle using the Pitch Diameter.
 $Circumference = \pi * D = 3.1416 * 1.5" = 4.7124"$
- Step 4.) Calculate the gear velocity using the gear velocity formula.
Velocity = 4.7124" x 166 RPM = 782.25 inches per minute or 65.188 ft per second.

Compare the Velocity in feet per second of the two gears. **The velocity of the 60-tooth drive gear is 65 ft. per minute, AND the velocity of the 36-tooth driven gear is 65 feet per minute. Gears in mesh rotate at different RPM but always at the same velocity.** If this were not true, then the teeth of the gears would strip off!

Calculating Ratios For Gear Trains with Multiple Gears

The preceding gear ratio problems dealt with two gears, or two gears and an Idler gear. An Idler gear does not affect the overall ratio between the two adjacent gears. The Idler gear merely changes the direction of the driven gear. We can however use compound gears to create multiplicative gear ratios that can dramatically increase torque or RPM.

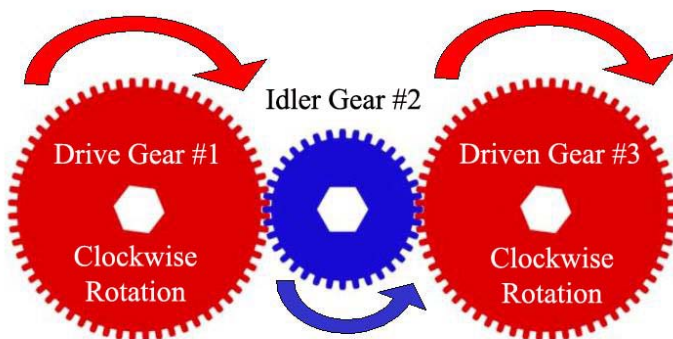

Fig. 6.3.1.11 The Idler Gear changes the Direction of the Driven Gear

In the example on the left, the ratio between the Drive Gear #1 and the Driven Gear #3 is 1:1. Both gears have the same number of teeth (60T). The Idler Gear #2 simply transmits the force from the Drive Gear #1 to the Driven Gear #2.

Calculating Ratios for Compound Gear Drives

Let's look at an example of a multiplicative gear reduction using a compound gear. A compound gear is made up of two gears solidly connected. Often they are machined from the same stock or keyed to the same shaft.

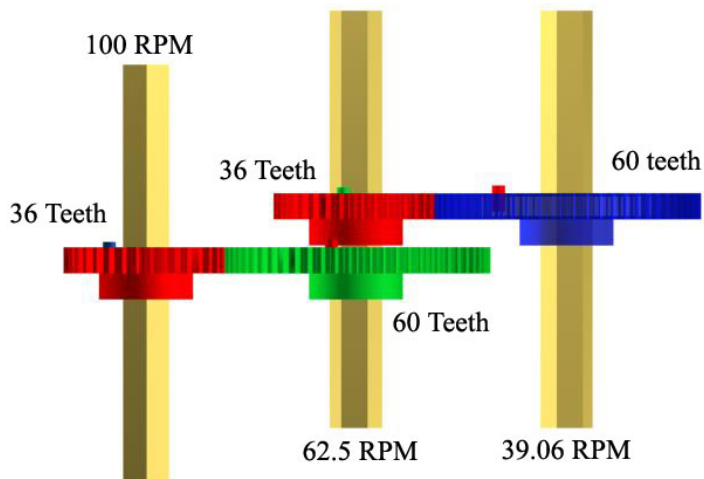

Fig. 6.3.1.12 Click the Image to View a Movie

The red gear on the left is the drive gear. This gear can also be called a pinion gear.

All the gears are rigidly fixed to the shafts. The green and red center gears form a compound gear.

The red drive gear spins at 100 RPM, and drives the 60 tooth green gear.

The ratio between the red (drive) gear and the green (driven) gear is 36T:60T or 1.6:1.

Since the green and red gears are affixed to the same shaft, they must both have the same RPM.

We can determine the RPM of the center shaft using the ratio between the red (drive) gear and the green (driven) gear. As noted previously the ratio is 1.6:1. Thus every time the red (drive) gear turns 1.6 revolutions, the green (driven) gear turns 1 revolution.

We find the RPM of the green (driven) gear by dividing $100 \text{ RPM} / 1.6 = 62.5 \text{ RPM}$.

Both the red and green center gears are turning at 62.5 RPM. The red center gear now drives the blue gear on the right.

The ratio between the red center gear and the blue gear is also 36T : 60T or 1.6:1.

We find the RPM of the blue (driven) gear by dividing $62.5 \text{ RPM} / 1.6 = 39.06 \text{ RPM}$.

The overall gear reduction is $100 \text{ RPM} / 39.06 \text{ RPM} = 2.56:1$

Note that if we MULTIPLY the two gear reductions, $1.6 \times 1.6 = 2.56$
Thus we can calculate the overall gear ration for gear trains with multiple gears by MULTIPLYING the individual gear reductions.

Try this gear problem. A 12 tooth gear drives a 48 tooth gear fixed to the center shaft. A 12T gear is fixed to the same center shaft. The 12T gear on the center shaft drives the blue 60 tooth gear. If the first gear in the train is rotating at 500 RPM, what is the RPM of the last gear?

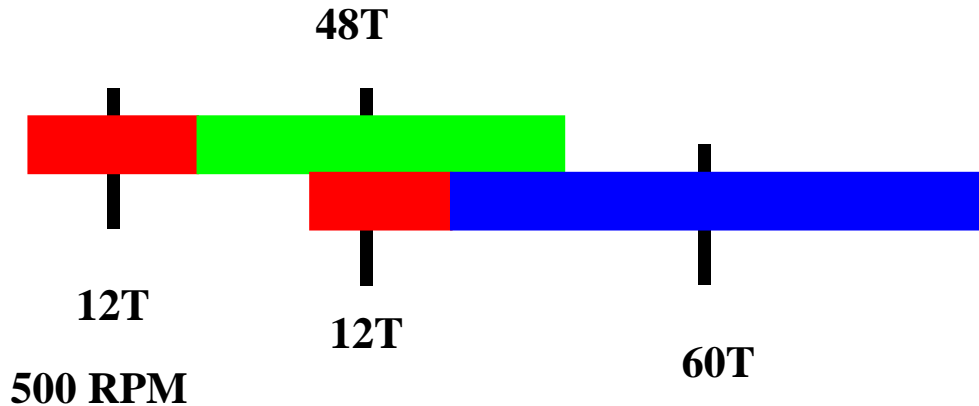

Fig. 6.3.1.13 Compound Gear Drive

Here is a different problem. Assume the 60T gear is the drive gear. It rotates at 500 RPM. What would the RPM of the the final gear be?

Calculating Torque in Gear Drives

Torque is a measure of the turning or twisting force that acts on axles, gears and shafts. Torque is proportional to the gear ratio.

This means that in a gear drive system with a 2.66:1 ratio, the torque transmitted from the drive gear to the driven gear is multiplied 2.66 times.

Assume that a gear of 36 teeth is driving a gear with 96 teeth. A ratio of 2.66:1 is produced. The torque applied to the shaft of the driven gear is multiplied by 2.66.

Conversely if a gear of 96 teeth is driving a gear with 36 teeth a ratio of 1:2.66 is produced. The torque applied to the shaft of the driven gear is divided by 2.66.

Looking at this mathematically we can say that a Ratio of 2.66:1 is equivalent to the fraction $\frac{2}{1}$ in order to find the torque multiple created by this ratio, simply multiply the drive gear torque by $\frac{2}{1}$.

On the other hand a Ratio of 1:2.66 is equivalent to the fraction $\frac{1}{2}$. To find the torque created by this ratio, simply multiply the drive gear torque by $\frac{1}{2}$.

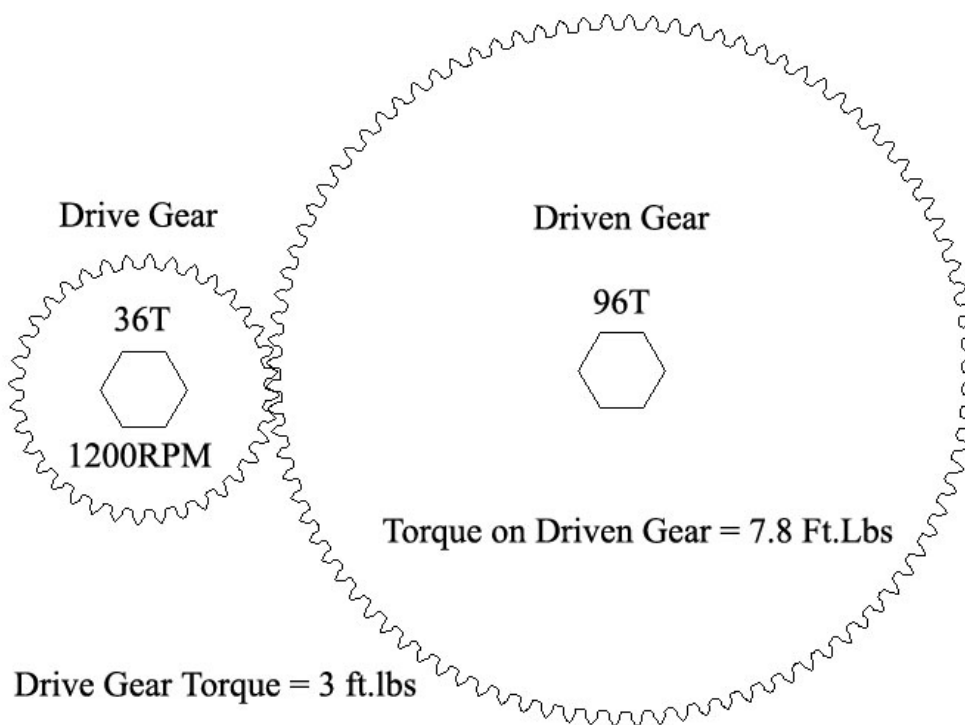

Fig. 6.3.1.14

Calculate the Transmitted Torques

The drive gear torque is 3 ft. lbs.

Step 1.) Calculate the gear ratio. $Ratio = \frac{DrivenGear}{DriveGear} = \frac{96}{36} = 2.66 : 1$

Step 2.) Multiply torque by the gear ratio = $\frac{2.66}{1} * 3 \text{ ft.lbs} = 7.8 \text{ ft. lbs. Torqu}$

Activities

Activity #1

Use the information in this lesson to make a careful, full sized sketch of a 8 pitch gear having 24 teeth. Use a compass, protractor, dividers, ruler and a straight edge. Accurately draw and label the following gear geometry.

Pitch Diameter	Pitch Circle	Addendum (Numerical Value)
Diametral Pitch (Pitch)	Number of Teeth	Dedendum
Whole Depth	Pressure Angle	Circular Pitch
Root Diameter	Circular Thickness	

Activity #2

The curved section of a gear tooth is called an involute curvature. An involute can be created by wrapping a string around a cylinder and tying a pencil on the free end. Use an 18" string, a pencil and a tin can to create involute designs on a piece of paper. Keep the paper in your notebook. Print your name, and the date you completed this assignment on the top of the page.

Activity #3

Download the GEARS-IDS Activity [document 6.3.1 Assemble Gear drive.pdf](#). Use the GEARS-IDS components and the instructions provided in this manual to construct a mobile robot chassis powered by an electric motor and a gear drive. This mobile chassis can be used for experiments associated with torque, velocity, robot control and more.

Note: This activity requires the GEARS-IDS optional Gear Set. Call 781-878-1512 to order the optional gear set. It is possible to construct this gear drive module with standard gears that can be obtained from a variety of sources.

Activity#4

Choose a gear drive related topic and independently prepare a 4-8 slide presentation that shares the knowledge and information you have gained through your research. Use graphics that you create in CAD, Photoshop, Power Point, etc. The expectation is that the presentation will be informative and interesting for the audience.

Activity#5

Create a spreadsheet program that can solve for 5 or more of the following gear values:

Pitch Diameter	Dedendum	Velocity of Driven Gear
Pitch Circle Circumference	Whole Depth	Velocity of Drive Gear
Diametral Pitch	Outside Diameter	Gear Ratios
Addendum	Root Diameter	
Base Circle	Circular Pitch	

Worksheets.

Refer to Worksheet 6.3.1.1

Links and Resources.

<http://auto.howstuffworks.com/gear1.htm> A well written and beautifully presented gear resource.

<http://stellar.mit.edu/SRSS/rss/course/2/sp09/2.007/> Slide shows about screws and gears. These documents are available through the Mechanical Engineering department at MIT. “Gifts” like these are available from many different universities.

<http://stellar.mit.edu/S/course/2/sp09/2.007/> This link is to the front page of the MIT 2.007 Design and Manufacturing course....the grand daddy of all the robot and engineering games we hear about today!

Rubric and Assessment

Rubrics define the levels of proficiency and achievement and describe what the student should know and be able to do as a result of participating in the lesson or activity.

The matrix on the following page is offered as an example of a Rubric written to reflect the objectives, standards and activities that are directly related to this Spur Gear lesson. Teachers are encouraged to modify this assessment tool to reflect the focus and activities they choose to include with this unit.

Assessment Rubric for Spur Gear Terms and Concepts

Proficiency	Meets/Exceeds Requirement	Meets Some of the Requirement	Meets little or None of the Requirement
Demonstrates a working knowledge of gear terminology through spoken, written and visual language			
Researches information about gear drives and generates ideas and questions by posing problems			
Gathers, evaluates, and synthesizes data from a variety of sources (e.g., print and non-print texts, artifacts, people) to communicate their understanding of Gear drives			
Presents clear and accurate sketches that detail and illustrate all the nomenclature associated with spur gears			
Calculates the key dimensions associated with gear design (<i>Fig. 6.3.1.5b</i>)			
Calculates and specify gear ratios			
Completes a working model of a gear drive and uses it to power a mechanism.			
Creates a design(s) using involute curves.			
Creates spreadsheet solutions for commonly used formulas			
Uses equivalent expressions to solve gear problems			

Additional Assessment Tools Include:

- Performance assessment.
- Portfolio (An organized chronology of individual achievement. This could be a notebook or a web page or a multimedia presentation)
- Work Sheets, Labs and design challenges.
- Examples of Spread Sheets to Solve Gear Related Problems
- Tests and Quizzes

Student Response/Journal Entry/Assignments

This is a listing of required documents or deliverables to be produced and present in each student's notebook.

1. Gear Sketches
2. Work Sheet
3. Research Presentation
4. Involute
5. Tests or Quizzes.

Media Content.

Slide Presentations

Notes and Comments