



Table of Contents

Special Characteristics, Points of Caution
 in Selecting and Using Bevel Gears page 228
 MHP High Ratio Hypoid Gears page 234
 MBSG Ground Spiral Bevel Gears page 236
 SBSG Ground Spiral Bevel Gears page 238
 MBSA(B) Finished Bore Spiral Bevel Gears page 240
 SBS Spiral Bevel Gears page 248
 SB(SBY) Bevel Gears page 252
 SB Bevel Gears & Pinion Shafts page 260
 SUB Stainless Steel Bevel Gears page 262
 PB Plastic Bevel Gears page 264
 DB Injection Molded Bevel Gears page 266
 BB Sintered Metal Busings page 266
 NISSEI KSP Ground Spiral Bevel Gears page 268

Catalog Number of KHK Stock Gears

The Catalog Number for KHK stock gears is based on the simple formula listed below.

Please order KHK gears by specifying their Catalog Numbers.

(Example)

Bevel Gears

M BSG 2 - 40 20 R

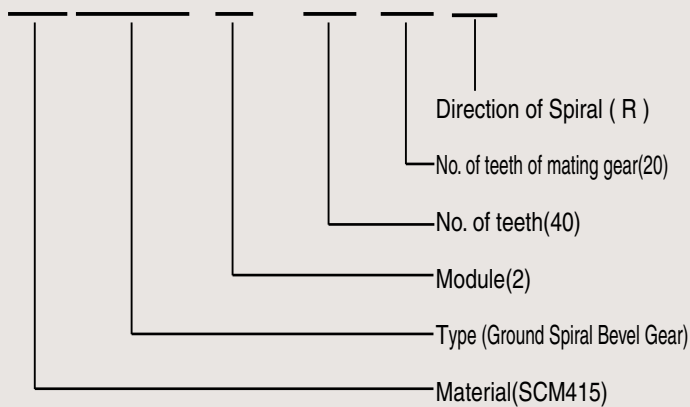

Material

S	S45C
M	SCM415
SU	SUS303
P	MC901
D	Duracon(M90-44)

Type

B	Bevel Gears
BS	Spiral Bevel Gears
BSG	Ground Spiral Bevel Gears
HP	High Ratio Hypoid Gears

7

Bevel Gears





Bevel Gears

Large Selection of Modules, Gear Ratios, Materials and Styles!



Characteristics

KHK stock bevel gears are available in two types, spiral and straight tooth, in gear ratios of 1.5 to 5, and are offered in a large variety of modules, numbers of teeth, materials and styles.

■ Main Features of Types of Bevel Gears Offered

The following table lists the main features for easy selection

Type	Catalog No.	Module	Gear Ratio	Material	Heat Treatment	Tooth surface finish	Precision JIS B 1704	Secondary Operations	Main Characteristic	
Hypoid Gear	MHP	1~1.5	15~200	SCM415	Gear tooth Carburizing	Cut	3	△	High speed reduction ratio, high efficiency, high rigidity and compact gear assembly.	
	Spiral bevel gears	MBSG	2~4	2	SCM415	Carburized (bore & hubs are masked) NOTE 2	Ground	2	△	High strength, abrasion-resistant and compact for high-speed & torque use.
		SBSG	2~4	1.5~3	S45C	Gear teeth induction hardened	Ground	2	△	Reasonably priced ground gear, yet remachinable except for the gear teeth.
		MBSA(B) NOTE 1	2~6	1.5~3	SCM415	Overall carburized NOTE 3	Cut	4	×	Ready to use without performing secondary operations. Strong and abrasion resistant.
		SBS	1~5	1.5~4	S45C	Gear teeth induction hardened	Cut	4	△	Large nos. of teeth and modules are offered in these affordable spiral bevel gears.
Straight bevel gears	SB·SBY	1~8	1.5~5	S45C (CB FC200)	—	Cut	3 (CB 4)	○	Popular series of straight bevel gears for many uses.	
	SUB	1.5~3	1.5~3	SUS303	—	Cut	3	○	Suitable for food machinery due to SUS303's rust-resistant quality.	
	PB	1~3	1.5~3	MC901	—	Cut	4	○	MC nylon products are light and can be used without lubricant.	
	DB	0.5~1	2	M90-44	—	Injection molded	8	△	Injection molded, mass-produced productions, suitable for office machines.	

NOTE 1: The catalog numbers with (B) at the end are identical in all features as the one without (B) except for bore and keyway dimensions.

NOTE 2: Even though the bore and the hub portions are masked during the carburization and can be modified, care should be exercised since the hardness is somewhat higher.

NOTE 3: MMSA(B) spiral bevel gears are carburized and do not allow secondary operations. However, the back surface of B7 style gears is masked during the process so that it is possible to drill and pin on this surface.

○ Possible △ Partly possible × Not possible

Combination of Our Know-How and Up-to-Date Manufacturing Techniques is at Your Disposal!

Our popular KHK stock bevel gears with a large selection of sizes and types are the results of our know-how and modern manufacturing capabilities. We deliver reliable, high precision, superior products to you.

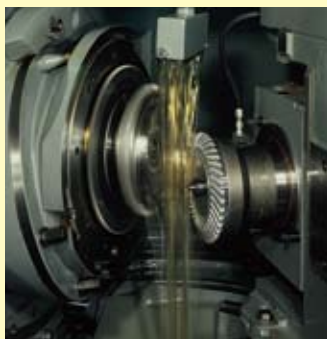



Selection Hints

Please select the most suitable products by carefully considering the characteristics of items and contents of the product tables. It is also important to read all applicable “CAUTION” notes shown below before the final selection.

1. Caution in Selecting the Mating Gears

Basically, KHK stock bevel gears should be selected as shown in the catalog in pairs (Ex: MBSG2-4020R should mate with MBSG2-2040L). But, for straight tooth bevel gears, there is some interchangeability with different series. For plastic bevel gears, we recommend metal mating gears for good heat conductivity.

■ Selection Chart for Straight Bevel Gears (○ Allowable × Not allowable)

Pinion \ Gear	SB	SUB	PB	DB
SB	○	○	○	×
SUB	○	○	○	×
PB	○	○	○	×
DB	×	×	×	○

■ Calculation of Bending Strength of Gears

Catalog No. \ Item	MBSG	MBSA(B)	SBSG SBS	SB SBY	SUB	PB	DB
Formula <small>NOTE1</small>	Formula of bevel gears on bending strength(JGMA403-01)					The Lewis formula	
No. of teeth of mating gears	No. of teeth of mating gears of same set					—	
Rotation	100min ⁻¹ (600min ⁻¹ for MBSG & SBSG)					100min ⁻¹	
Durability	Over 10 ⁷ cycles					—	
Impact from motor	Uniform load					Allowable bending stress	
Impact from load	Uniform load						
Direction of load	Bidirectional						
Allowable bending stress at root σ_{Flim} <small>NOTE2</small>	31.33kgf/mm ²	31.33kgf/mm ²	14kgf/mm ²	12.67kgf/mm ²	7kgf/mm ²	1.15kgf/mm ² (40°C with no lubricant)	<small>NOTE3</small> m 0.5 4.5 m 0.8 4.0 m 1.0 3.5 kgf/mm ²
Safety factor K_R	1.2						

■ Calculation of Surface Durability (Except those in common with bending strength)

Formula <small>NOTE1</small>	Formula of bevel gears on surface durability (JGMA404-01)				
Kinematic viscosity of lubricant	100cSt(50°C)				
Gear support	Shafts & gear box have normal stiffness, and gears are supported on one end				
Allowable Hertz stress σ_{Hlim}	166kgf/mm ²	166kgf/mm ²	90kgf/mm ²	49kgf/mm ²	41.3kgf/mm ²
Safety factor C_R	1.15				

NOTE 1: The gear strength formula is based on JGMA (Japanese Gear Manufacturers Association) specifications. “MC Nylon Technical Data” by Nippon Polyenco Limited and “Duracon Gear Data” by Polyplastic Co. Also, the units (min⁻¹) of number of rotations and unit (kgf/mm²) of stress are adjusted to the units needed in the formula.

NOTE 2: Since the load is bidirectional, the allowable bending stress at root σ_{Flim} , used in JGMA 403-01 formula is set to 2/3 of the value.

NOTE 3: The value for DB m0.5 was assumed by KHK.

4. Other Points to Consider in the Selection Process

See the similarly titled section for miter gears.

2. Caution in Selecting Gears Based on Gear Strength

The gear strength values shown in the product pages were computed by assuming a certain application environment. Therefore, they should be used as reference only. We recommend that each user computes their own values by applying the actual usage conditions. The table below contains the assumptions established for these products in order to compute gear strengths.

CAUTION: The allowable torque of MHP High Ratio Hypoid Gears is the actual measured value when the pinion is rotating at 600 min⁻¹.

3. Caution with Regard to the Special Characteristics of Bevel Gears

- ① MBSA(B) finished bore spiral bevel gears are carburized throughout so that they do not permit any secondary operations. However, the back surface of B7 style gears (ring type) is masked during the process so that it is possible to drill and pin on this surface.
- ② The keyway sizes of MBSA(B) finished bore spiral bevel gears are made according to JIS B 1301, medium quality (Js9), but the final heat treating may cause some deformation.
- ③ The bore of SBS spiral bevel gears may somewhat be deformed due to heat treatment and do not reach H7 tolerance.
- ④ Due to the characteristics of the material, PB plastic bevel gears' product quality may be affected by heat or moisture absorption.



Bevel Gears



Application Hints

In order to use KHK stock gears safely, carefully read the Application Hints before proceeding. For “Notes on Starting Operations” and “Other Points to Consider in Applications”, please see the Application Hints of Miter Gear Selection.

1. Caution on Performing Secondary Operations

- ① If you are reborring, it is important to pay special attention to locating the center in order to avoid runout.
- ② The reference datum for gear cutting is the bore. Therefore, it is best to use the bore for locating the center. If it is too difficult to do for small bores, the alternative is to use one spot on the bore and the runout of the side surface.
- ③ If reworking using scroll chucks, we recommend the use of new or rebored jaws for improved precision. Please exercise caution not to crush the teeth by applying too much pressure. Any scarring will cause noise during operation.

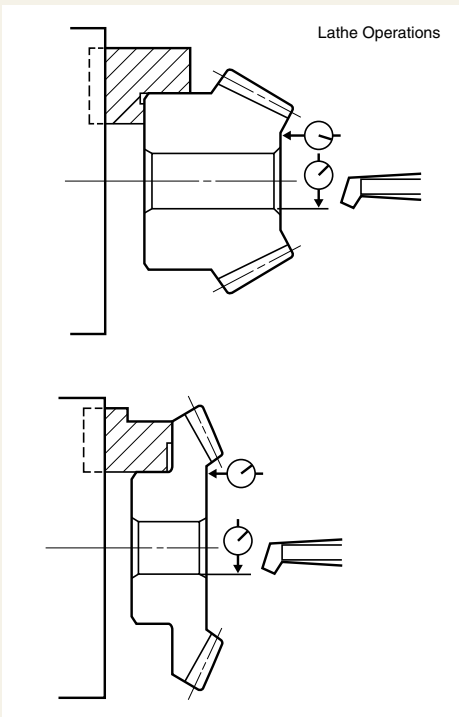

- ④ The production of bevel gears module 2.5 and over with a pinning hole on the back of the hub in non-ground teeth has been phased out as of August 2003. However, we may have some stock of this configuration.

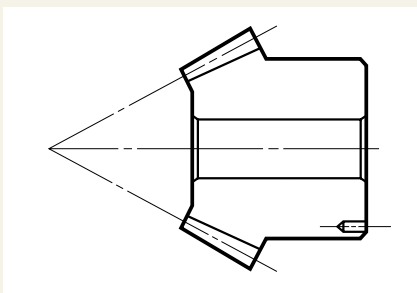

- ⑤ MBSA(B) finished bore spiral bevel gears are carburized throughout, so that no secondary operations can be performed (except B7 style items). For items with induction hardened teeth, such as SBSG and SBS series, the hardness is high near the tooth root. When machining the front end, the machined area should be 4 to 6mm smaller than the dimension, J.

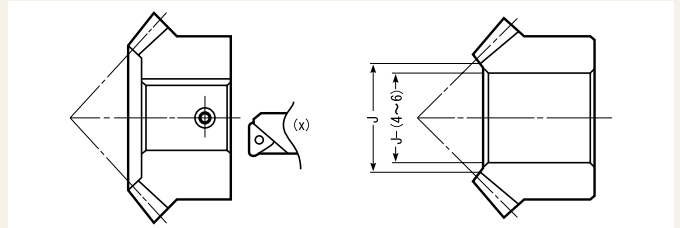

- ⑥ For tapping and keyway operations, see the examples given in “1. Caution on Performing Secondary Operations” in KHK Stock Spur Gear section. When cutting keyways, to avoid stress concentration, always leave radii on corners.
- ⑦ PB plastic bevel gears are susceptible to changes due to temperature and humidity. Dimensions may change between during and after remachining operations.
- ⑧ When heat treating S45C products, it is possible to get thermal stress cracks. It is best to subject them to penetrant inspection afterwards. While the teeth strength may increase four fold, the precision of the gear will drop approximately one grade.
- ⑨ For the handling conveniences, SB and SBY series listed below has the tapped holes (180° apart, 2 places) on the holding surface.

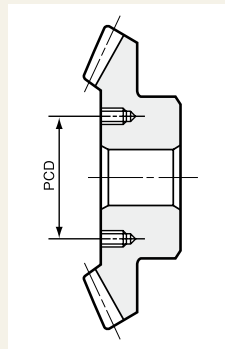

Catalog No.	PCD(mm)	Tap Size
SB6-4515	130	M10 deep 15
SBY8-4020	180	M10 deep 20
SBY8-4515	210	M10 deep 20
SBY5-6015	180	M10 deep 15
SBY6-6015	220	M10 deep 20



2. Points of Caution in Assembling

① Since bevel gears are cone shaped, they produce axial thrust forces. Especially for spiral bevel gears, the directions of thrust change with the hand of spiral and the direction of rotation. This is illustrated below. The bearings must be selected properly to be able to handle these thrust forces.

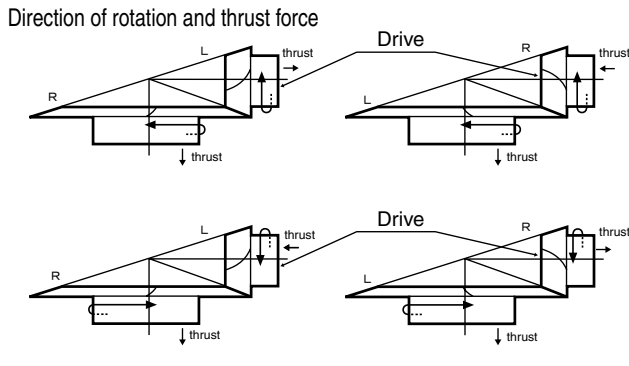

- ② KHK stock bevel gears are designed such that, when assembled according to the specified mounting distance with a tolerance of H7~H8, the backlash shown in the table is obtained. Mounting distance error, offset error and shaft angle error must be minimized to avoid excessive noise and wear. For various conditions of teeth contact, please see page 198 "Correct Tooth Contact" and "Incorrect Tooth Contact".
- ③ If a bevel gear is mounted on a shaft far from the bearings, the shaft may bend. We recommend mounting bevel gears as close to the bearings as possible. This is especially important since most bevel gears are supported on one end. The bending of shafts will cause abnormal noise and wear, and may even cause fatigue failure of the shafts. Both shafts and bearings must be designed with sufficient strength.
- ④ Due to the thrust load of bevel gears, the gears, shafts and bearings have the tendency to loosen up during operation. Bevel gears should be fastened to the shaft with keys and set screws, taper pins, step shafts, etc.
- ⑤ When installing MBSA(B) spiral bevel gears in B7 style (ring type), always secure the gears onto the mounting base with taper pins to absorb the rotational loads. It is dangerous to secure with bolts only.

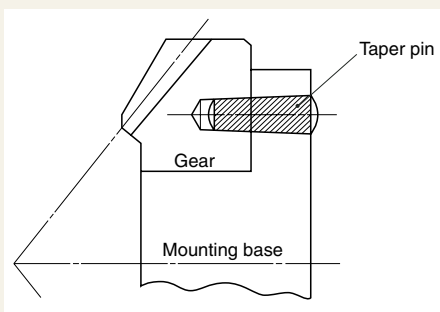

PRODUCT IMPROVEMENT ANNOUNCEMENT

In order to increase the gear strength of KHK standard Bevel Gears, starting in June 2004, the following changes have been introduced. During this transition, some of the specifications will change.

1. Applicable Series

MBSG Ground Spiral Bevel Gears – (8 Items)

2. Improvement Details

Increase in gear strength (Approximately 15% higher bending strength compared to previous one)

3. Change in the specifications

	Before	After
Heat treatment	Teeth induction hardened after carburizing	Carburizing (bore & hub portion masked)
Surface Treatment	Black oxide	No black Oxide

The corner tips of the gear-teeth of KHK stock Bevel Gears are machine chamfered for safety and for prevention of damages.

■ The chamfering of the corner gear tips for bevel gear (unit: mm)

Module	Outside edge R	Inside edge R
0.5 up to 1	0.5	all burrs removed
1 up to 2.5	1	0.5
2.5 up to 5	2	1
over 5	3	1.5

Example of KHK Gear Applications



Components of automated line (Bevel Gears)



Bevel Gears

Features of MHP High Ratio Hypoid Gears

A pair of MHP high-ratio hypoid gears are able to produce an amazing speed of reduction of 200:1 in one stage.

1. Total-cost reduction

The MHP provides a compact gearing body replacing several stages of reduction gears. This reduces the cost sharply.

2. High efficiency

Compared to worm gear drives, the MHP has less sliding contact. The resulting higher efficiency allows the use of smaller motors (See the graph on the right).

3. High rigidity

The carburized hypoid gears lead to smaller size than comparable worms gears.

4. Compact gear assembly

The size of the gear housing is nearly the same as outer diameter of the large gear. (See the diagrams below)

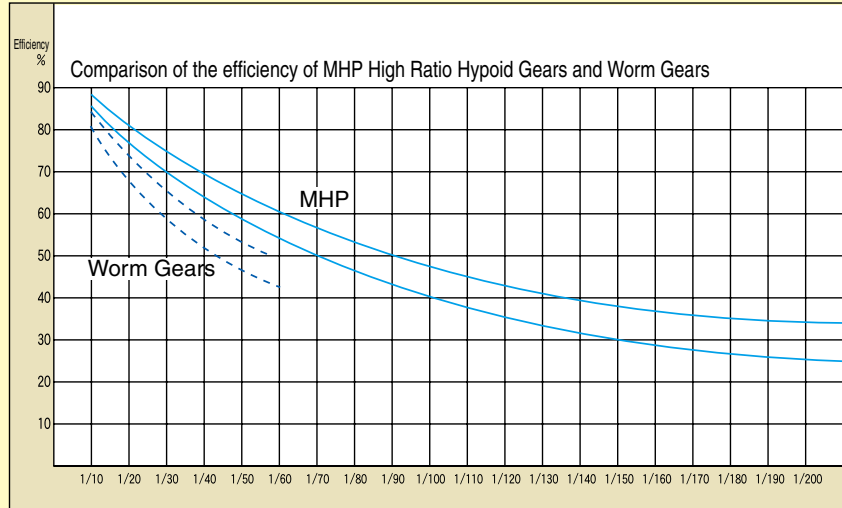

Comparison of MHP and worm Gears

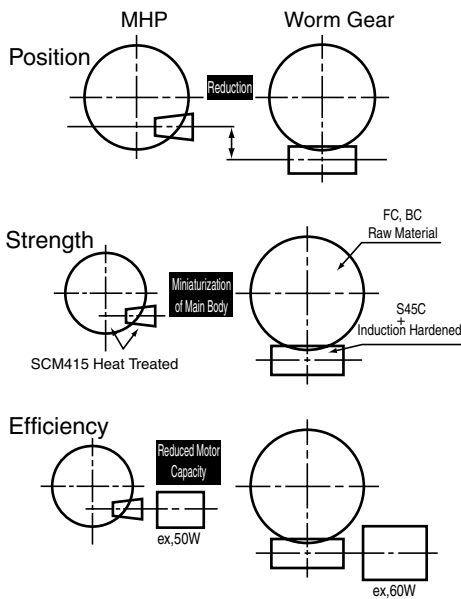

How to determine the radial and thrust loads

Before using the MHP high-ratio hypoid gears, be sure to confirm the direction of radial and thrust loads. Following equations are used to compute these loads. The radial and thrust load coefficients are given on the product pages.

Radial load calculation

W_{RP} : Radial load on the pinion or L(N)

$$W_{RP} = W_{KP} \times T_G \times \frac{n}{z}$$

Where

W_{KP} : Radial load coefficient of pinion or L (given on the product pages)

T_G : Torque of gear or R(N-m)

n : Number of teeth of pinion or L

z : Number of teeth of gear or R

W_{RG} : Radial load on the gear or R(N)

$$W_{RG} = W_{KG} \times T_G$$

Where

W_{KG} : Radial load coefficient of gear or R (given on the product pages)

T_G : Torque of gear or R(N-m)

Thrust load calculation

W_{XP} : Thrust load on the pinion or L(N)

$$W_{XP} = W_{NP} \times T_G \times \frac{n}{z}$$

Where

W_{NP} : Thrust load coefficient of pinion or L (given on the product page)

T_G : Torque of gear or R(N-m)

n : Number of teeth of pinion or L

z : Number of teeth of gear or R

W_{XG} : Thrust load of gear of R(N)

$$W_{XG} = W_{NG} \times T_G$$

Where

W_{NG} : Thrust load coefficient of gear or R (given on the product pages)

T_G : Torque of gear or R(N-m)

R: Right-hand thread at speed ratio 1/1

L: Left-hand thread at speed ratio 1/1

Variations in tooth contact due to poor alignment of gears

If the gear engagement position is out of the normal position, variations in tooth contact, as illustrated below, may appear.

(1) Tooth contact in case of a shaft-angle error

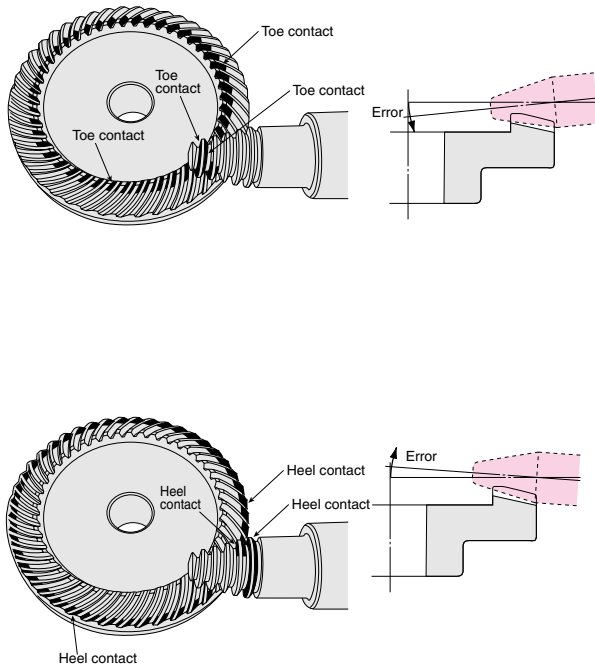

(2) Tooth contact in case of a shaft-offset error

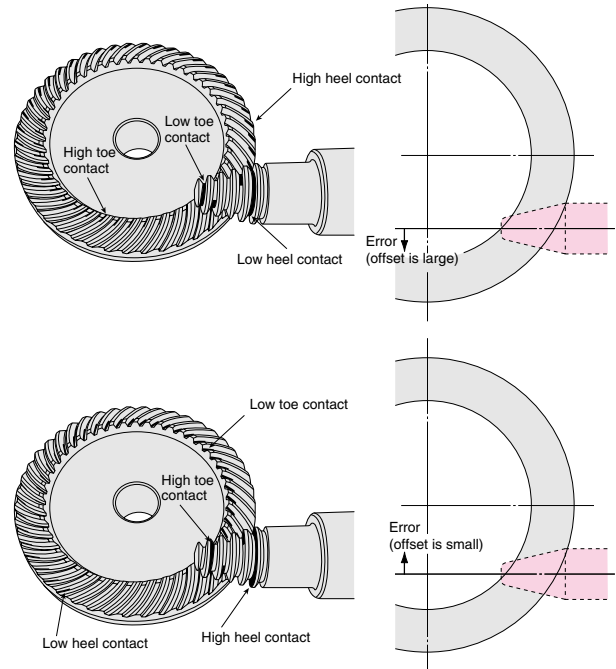

(3) Tooth contact in case of a pinion set position error

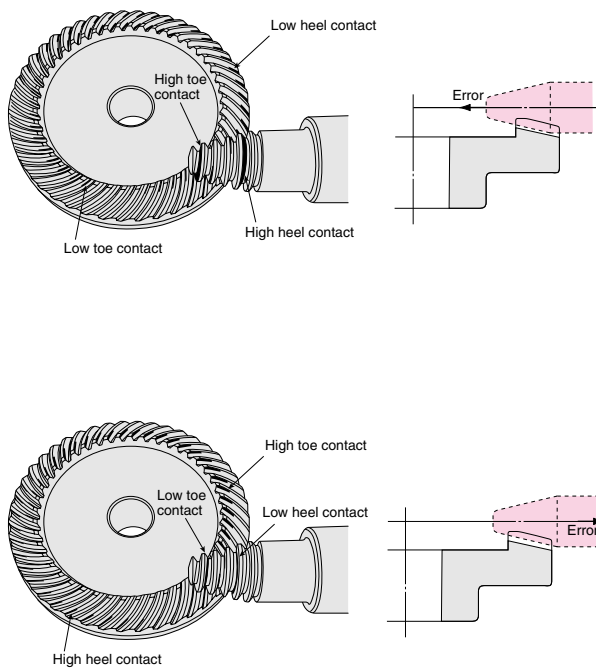

(4) Tooth contact in case of a gear set position error

